



Enriching Lives

END SUCTION PUMPS

TYPE - DB



CE

KIRLOSKAR BROTHERS LIMITED

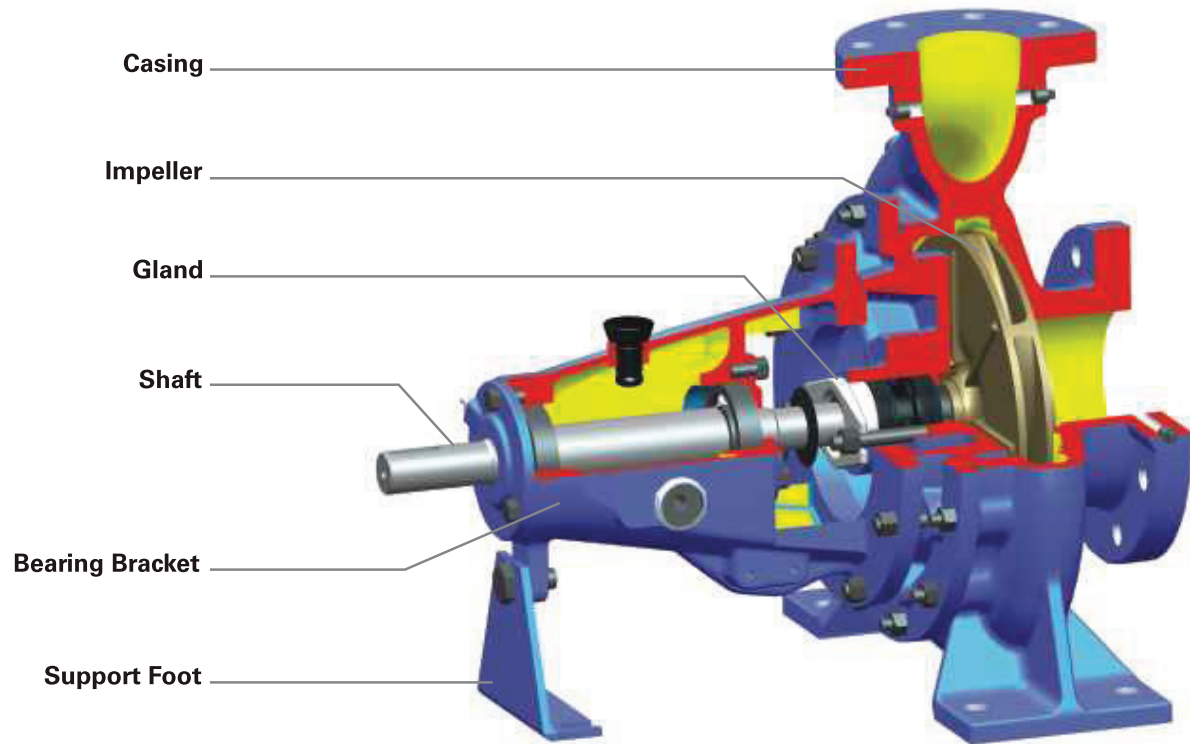

RANGE

Delivery size : up to 150 mm
 Capacity : up to 550 m³/hr
 Head : up to 100 metres

APPLICATIONS

Circulation of water in industries, Air-conditioning plants, Power stations, Mine water, Lift irrigation, Sprinkler systems, Fire fighting, Booster services, Pumping brines, Oils etc. for liquids having temperature in the range of -10°C to 100°C.

FEATURES

These are single stage, single suction, horizontal shaft type. They are made in accordance with DIN 24255. Models are available to operate at 1450 rpm and 2900 rpm at 50 Hz

Casing :

End suction, volute type with top centreline discharge. Suction and discharge nozzles as well as the supporting feet are cast integral with the casing.

Impeller :

Enclosed type dynamically balanced. Hydraulic balance is achieved either by back vanes for smaller impellers and by balancing hole with back wear rings for large impellers.

Shaft :

Three driving units cover complete range. The high tensile steel shaft accurately machined and ground is supported by anti-friction bearings. The shaft is protected by shaft sleeve from wear in stuffing box area.

Stuffing Box :

The stuffing box can be sealed by gland packing or by mechanical seal.

Bearing :

Deep groove ball bearings are provided. Standard lubrication is grease. Oil lubrication against requirement.

Direction of Rotation :

Clockwise viewed from driving end.

Drive :

Suitable for coupling with electric motors, engines directly or through belt drives.

Flanges :

Standard : Drilling as per BS EN 1092-2 (DIN 2533 ND 16)

Optional : Drilling as per IS/BS/ASA/DIN available with suitable pressure rating.

GENERAL DIMENSIONS / MOUNTING DETAILS

Outline Drawing

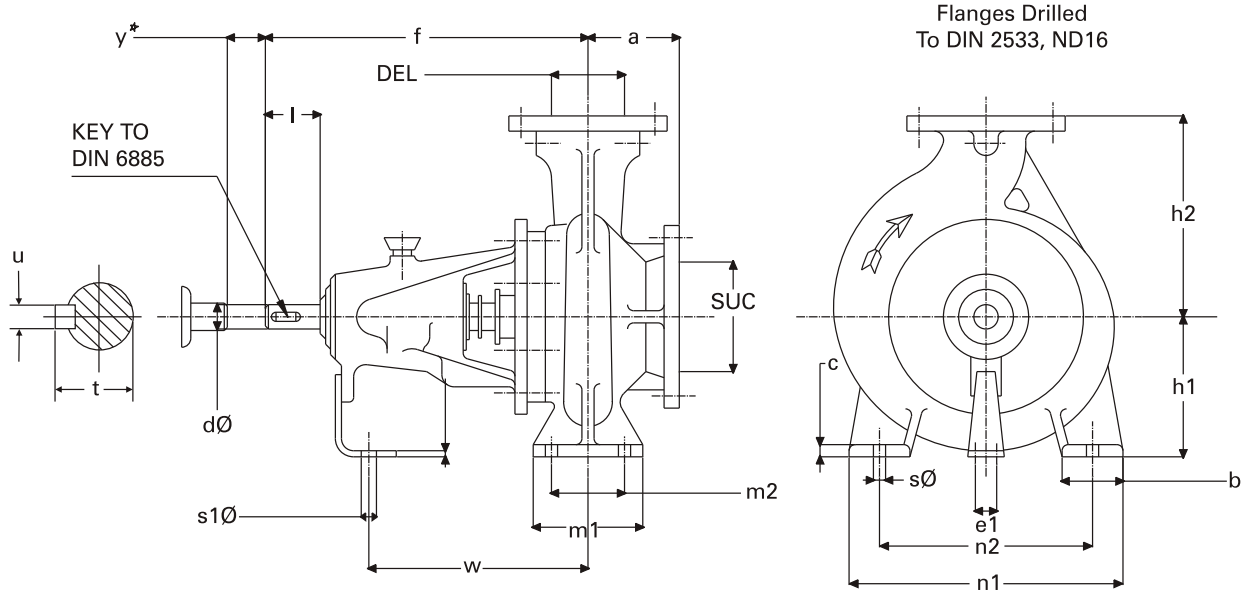

PUMP MODEL	UNIT NO.	SUC.	DEL.	PUMP MOUNTING DIMENSIONS														SHAFT END					WT. KG
				a	f	h1	h2	b	c	m1	m2	n1	n2	sØ	e1	slØ	w	dØ	l	t	u	y	
32/13	25	50	32	80	360	112	140	50	14	100	70	190	140	14	100	14	267	24	50	27	8	100	28
32/16	25	50	32	80	360	132	160	50	14	100	70	240	190	14	100	14	267	24	50	27	8	100	34
32/20	25	50	32	80	360	160	180	50	14	100	70	240	190	14	110	14	267	24	50	27	8	100	41
32/26	25	50	32	100	360	180	225	65	14	125	95	320	250	14	110	14	267	24	50	27	8	100	59
40/13	25	65	40	80	360	112	140	50	14	100	70	210	160	14	100	14	267	24	50	27	8	100	29
40/16	25	65	40	80	360	132	160	50	14	100	70	240	190	14	100	14	267	24	50	27	8	100	36
40/20	25	65	40	100	360	160	180	50	14	100	70	265	212	14	110	14	267	24	50	27	8	100	44
40/26	25	65	40	100	360	180	225	65	14	125	95	320	250	14	110	14	267	24	50	27	8	100	61
50/13	25	65	50	100	360	132	160	50	14	100	70	240	190	14	100	14	267	24	50	27	8	100	32
50/16	25	65	50	100	360	160	180	50	14	100	70	265	212	14	110	14	267	24	50	27	8	100	38
50/20	25	65	50	100	360	160	200	50	14	100	70	265	212	14	110	14	267	24	50	27	8	100	46
50/26	25	65	50	100	360	180	225	65	14	125	95	320	250	14	110	14	267	24	50	27	8	100	63
50/32K	35	65	50	125	470	225	290	80	16	160	120	400	315	18	110	14	342	32	80	35	10	140	83
65/13	25	80	65	100	360	160	180	65	14	125	95	280	212	14	110	14	267	24	50	27	8	100	39
65/16	25	80	65	100	360	160	200	65	14	125	95	280	212	14	110	14	267	24	50	27	8	100	43
65/20	25	80	65	100	360	180	225	65	14	125	95	320	250	14	110	14	267	24	50	27	8	100	52
65/26	35	80	65	100	470	200	250	80	16	160	120	360	280	18	110	14	342	32	80	35	10	140	81
65/32	35	80	65	125	470	225	280	80	16	160	120	400	315	18	110	14	342	32	80	35	10	140	100
80/16	25	100	80	125	360	180	225	65	14	125	95	320	250	14	110	14	267	24	50	27	8	100	53
80/20	35	100	80	125	470	180	250	65	14	125	95	345	280	14	110	14	342	32	80	35	10	140	70
80/26	35	100	80	125	470	200	280	80	16	160	120	400	315	18	110	14	342	32	80	35	10	140	91
80/32	35	100	80	125	470	250	315	80	16	160	120	400	315	18	110	14	342	32	80	35	10	140	107
100/20	35	125	100	125	470	200	280	80	16	160	120	360	280	18	110	14	342	32	80	35	10	140	85
100/26	35	125	100	140	470	225	280	80	16	160	120	400	315	18	110	14	342	32	80	35	10	140	103
100/32	35	125	100	140	470	250	315	80	16	160	120	400	315	18	110	14	342	32	80	35	10	140	116
100/40	45	125	10	140	530	280	355	100	18	200	150	500	400	23	110	14	370	42	110	45	12	140	177
125/26	35	150	125	140	470	250	355	80	16	160	120	400	315	18	110	14	342	32	80	35	10	140	110
125/32	45	150	125	140	530	280	355	100	18	200	150	500	400	23	110	14	370	42	110	45	12	140	151
125/40	45	150	125	140	530	315	400	100	18	200	150	500	400	23	110	14	370	42	110	45	12	140	188
150/32	45	200	150	160	530	280	400	100	18	200	150	550	450	23	110	14	370	42	110	45	12	140	170
150/40	45	200	150	160	530	315	450	100	18	200	150	550	450	23	110	14	370	42	110	45	12	140	205

*Y - Backpullout distance required between motor shaft end and pump shaft
All Dimensions are in mm

CROSS-SECTION VIEW

DB Pump

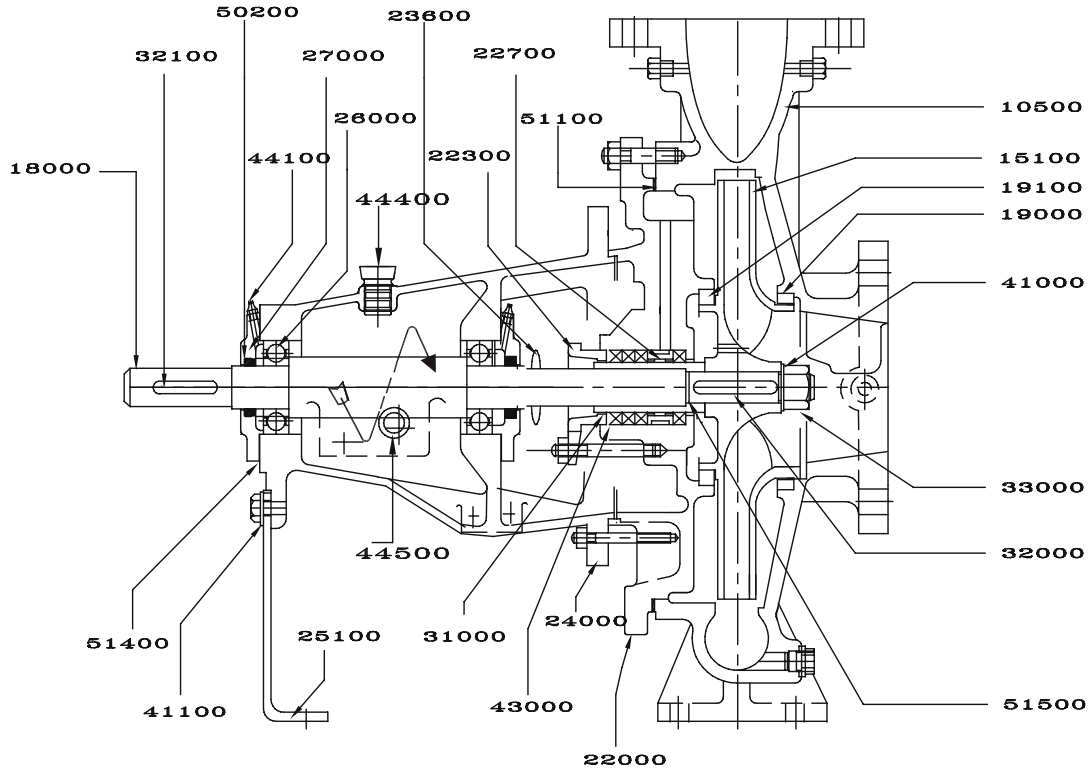

INTERCHANGEABILITY OF COMPONENTS

PART NO.	NAME OF PART	TOTAL NO.OF PARTS	PUMP MODEL																															
			32/13	40/13	50/13	65/13	32/16	40/16	50/16	65/16	80/16	32/20	40/20	50/20	65/20	32/26	40/26	50/26	80/20	100/20	65/26	80/26	100/26	125/26	50/32K	65/32	80/32	100/32	125/32	150/32	100/40	125/40	150/40	
			UNIT 25										UNIT 35										UNIT 45											
10500	PUMP CASING	31	1	2	3	4	5	6	7	8	9	10	11	12	13	14	15	16	17	18	19	20	21	22	32	23	24	25	26	27	28	29	30	
15100	IMPELLER	31	1	2	3	4	5	6	7	8	9	10	11	12	13	14	15	16	17	18	19	20	21	22	32	23	24	25	26	27	28	29	30	
18000	SHAFT	3	1										2										3											
19000	CASING RING	10	1	2	3	4	1	2	3	4	5	2	2	3	4	2	3	4	5	6	4	5	6	7	15	5	8	6	7	9	6	7	9	
22000	CASING COVER	10	1	1	1	1	2	2	2	2	2	3	3	3	3	4	4	4	4	5	5	6	6	7	7	8	8	8	8	9	9	10	10	10
22300	GLAND	3	1										2										3											
22700	LANTERN RING	3	1										2										3											
24000	BEARING HOUSING	4	1	1	1	1	2	2	2	2	2	1	1	1	1	2	2	2	3	3	3	3	3	3	3	3	3	3	3	4	4	4	4	4
25100	SUPPORT FOOT	8	1	1	2	3	2	2	3	3	4	3	3	3	4	4	4	4	4	3	4	4	4	5	6	5	5	6	6	7	7	7	8	8
26000	BEARING	3	1										2										3											
27000	BEARING COVER	3	1										2										3											
31000	SHAFT SLEEVE	3	1										2										3											
32000	IMPELLER KEY	3	1										2										3											
32100	COUPLING KEY	3	1										2										3											
33000	IMPELLER NUT	3	1										2										3											
41000	LOCK WASHER	3	1										2										3											
19100	BACK WEAR RING	7																							15	12	13	14	10	9	11	10	9	

MECHANICAL SEAL ARRANGEMENT

Typical Cross Sectional Drawing

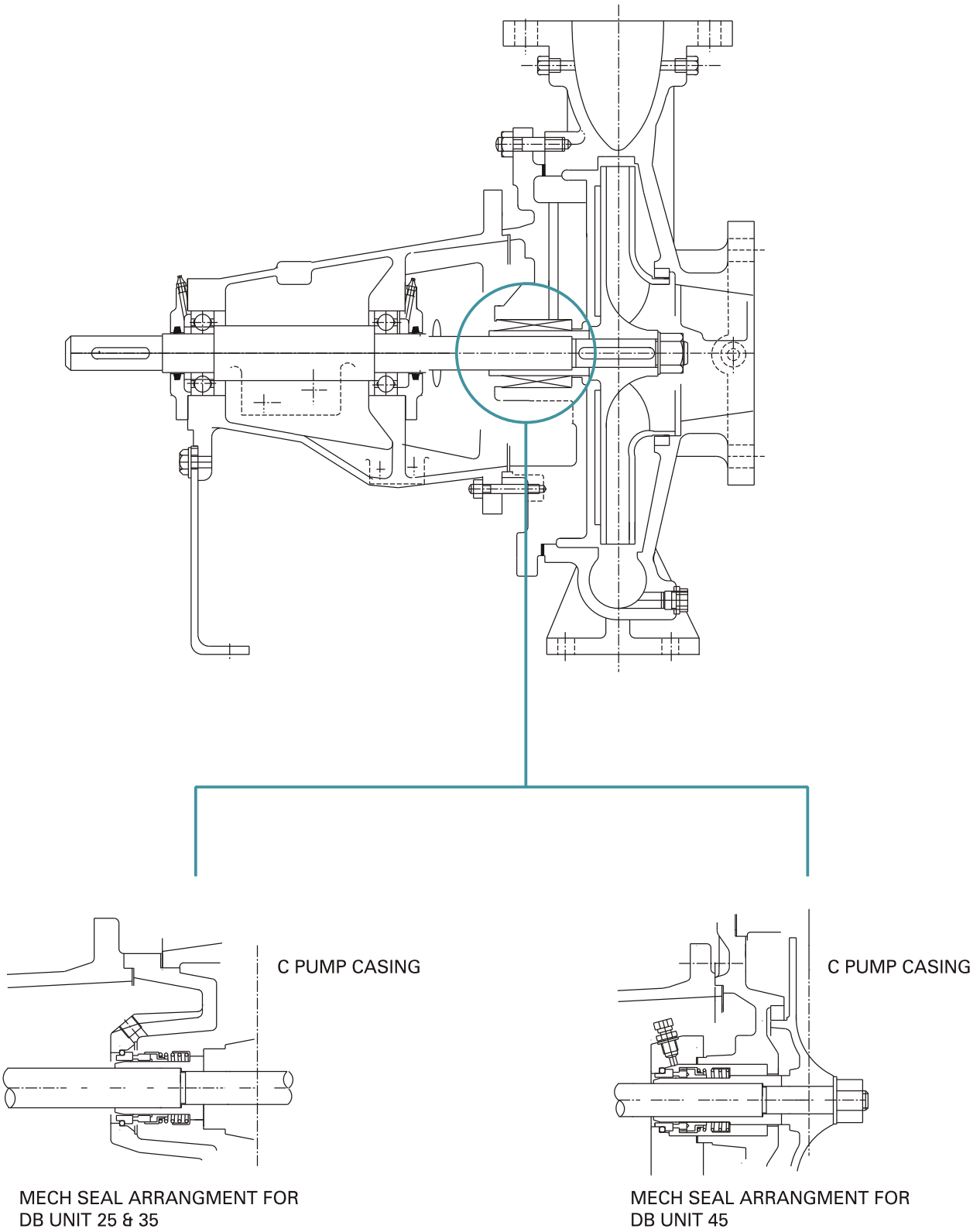

MATERIALS

MATERIAL OF CONSTRUCTION

Casing	Cast Iron / Bronze / Phosphor Bronze
Casing Cover	Cast Iron / Bronze / Phosphor Bronze
Impeller	Cast Iron / Bronze / Phosphor Bronze
Wear Ring	Cast Iron / Bronze
Shaft	Carbon Steel / Stainless Steel
Shaft Sleeve	Stainless Steel / Bronze
Lantern Ring	Nylon
Gland	Cast Iron / Bronze

MATERIAL STANDARDS - GENERAL INFORMATION

Material Type	Indian Standard (IS)	American standard (ASTM)	DIN
Cast Iron			
Cast Iron	IS 210 Gr. FG 260	ASTM A48 Class 40	(0.6025)DIN 1691 GG25
Spheroidal Graphite Cast Iron			
SG Iron (Ductile Iron)	IS 1865 Gr 400/15	A536, 60-40-18	(0.7040)DIN1693 GGG40
SG Iron (Ductile Iron)	IS 1865 Gr 500/7	A536, 65-45-12	(0.7050)DIN1693 GGG50
Carbon steel			
Carbon steel (Wrought)	IS 1570 (part II) Gr. 40C8	ASTM A107 Gr. 1040	(1.1186)C40E/CK40
Carbon steel (Wrought)	IS 1570 (part II) Gr. 20C8	ASTM A107 Gr. 1020	(1.0402)C22
MS Steel	MS IS 2062 - Fe 410 W A	ASTM-A283 GR.D	DIN 1700 GR ST4-2 FABRICATED STEEL44
Cast Steel Grades			
Cast steel		ASTMA 216 Gr. WCB	1.0619(GS-C25)
Cast Stainless Steel			
Stainless Steel CF8M	IS 3444 Gr. 4	ASTMA 351 Gr. CF8M	1.4408(GX5CrNiMo19-11-2)
Stainless Steel CF8M	IS 3444 Gr. 4	ASTMA 743 Gr. CF8M	1.4408(GX5CrNiMo19-11-2)
Stainless Steel CF3M	IS 3444 Gr. 16	ASTMA 351 Gr. CF3M	1.4409(GX2CrNiMo19-11-2)
Stainless Steel CF3M	IS 3444 Gr. 16	ASTMA 743 Gr. CF3M	1.4409(GX2CrNiMo19-11-2)
Stainless Steel CF8	IS 3444 Gr. 1	ASTMA 351 Gr. CF8	1.4301(X5CrNi18-10)
Stainless Steel CF3	IS 3444 Gr. 15	ASTMA 351 Gr. CF3	1.4306(X2CrNi19 11)
Cast Chromium StainlessSteel			
Stainless Steel CA15	IS 3444 Gr. 10	ASTMA 217 Gr. CA15	1.4106&1.448(DIN17445 GX12Cr14)
Stainless Steel CA15	IS 3444 Gr. 10	ASTMA 743 Gr. CA15	1.4106&1.448(DIN17445 GX12Cr14)
Stainless Steel CA6NM	IS 3444 Gr. 24	ASTMA 487 Gr. CA6NM	1.4313&1.4317(GX5CrNiMo13-4)
Stainless Steel CA6NM	IS 3444 Gr. 24	ASTMA 743 Gr. CA6NM	1.4313&1.4317(GX5CrNiMo13-4)
Chromium StainlessSteel Round Bar Material			
Stainless steel 410	IS 1570 (part V) Gr. X12Cr12	ASTMA 276 type 410	1.4006(X10Cr13)
Stainless steel 420	IS 1570 (part V) Gr. X20Cr13	ASTMA 276 type 420	1.4021(X20Cr13)
Stainless steel 431	IS 1570 (part V) Gr. X15Cr16Ni2	ASTMA 276 type 431	1.4057(X20CrNi17)
Stainless steel 316	IS 1570 (part V) Gr. X04Cr17Ni12Mo2	ASTMA 276 type 316	1.4401(X5CrNiMo17122)
Stainless steel 316L	IS 1570 (part V) Gr. X02Cr17Ni12Mo2	ASTMA 276 type316L	1.4404(X2CrNiMo1810)
Cast Duplex Steel			
Duplex Steel 1A		ASTMA 890 Gr. CD4MCu	25Cr-5Ni-Mo-Cu
Duplex Steel 2A		ASTMA 890 Gr. CE8MN	24Cr-10Ni-Mo-N
Duplex Steel 3A		ASTMA 890 Gr. CD6MN	25Cr-5Ni-Mo-N
Super Duplex steel 4A		ASTMA 890 Gr. CD3MN	25Cr-7Ni-Mo-N
Super Duplex steel 5A		ASTMA 890 Gr. CE3MN	24Cr-10Ni-Mo-N
Non Ferious Materials			
Bronze	IS 318 Gr. LTB2 (CuSn5Zn5Pb5C)	ASTMB 584 - C90500	DIN 1705 Rg 5
Phosphor Bronze	IS 28 Gr. 1 (CuSn11PC)		
Zinc Free Bornze	IS 28 Gr. 1 (CuSn10C)		

Family Curves of DB Pump at 1450 rpm-50Hz

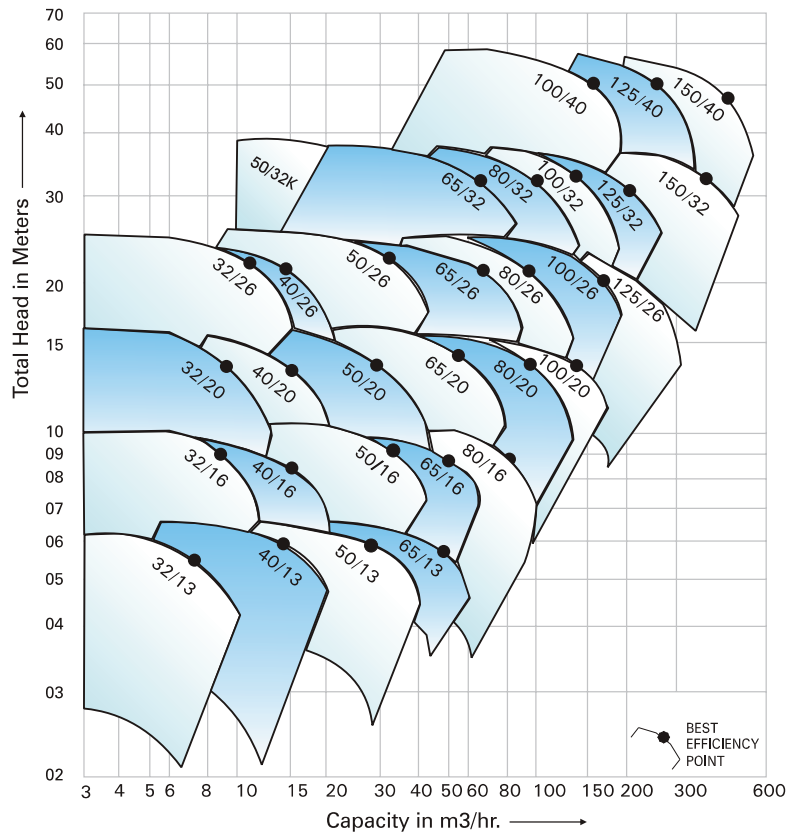

Family Curves of DB Pump at 2900 rpm-50Hz

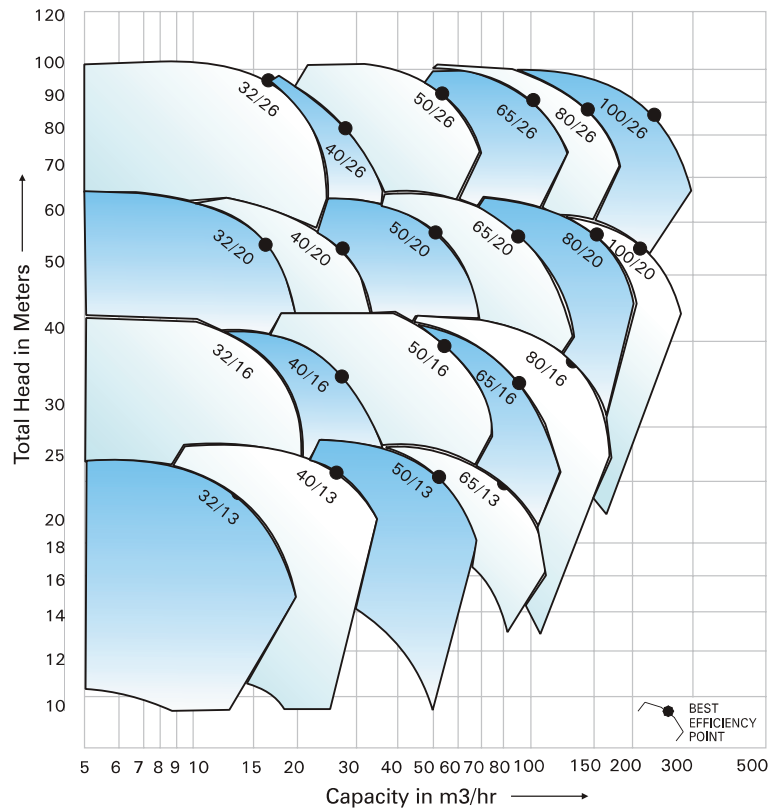

OUR GLOBAL PRESENCE



As we are constantly endeavouring to improve the performance of our products/ equipment, we reserve the right to make alterations from time to time and as such our products/ equipment may differ from that detailed in this publication. For latest information you may get in touch with our Regional Sales Offices.



Enriching Lives

KIRLOSKAR BROTHERS LIMITED

CORPORATE OFFICE :

"YAMUNA", Survey No. 98 (3/7), Baner,
Pune - 411045, INDIA
Tel.: +91 20 27214444 Fax: +91 20 27211117
email: kblin@kbl.co.in website: www.kbl.co.in

WORKS :

Kirloskarvadi 416308 Dist. Sangli
Maharashtra, INDIA
Tel.: +91 2346 222301 to 222305
Fax: +91 2346 222311

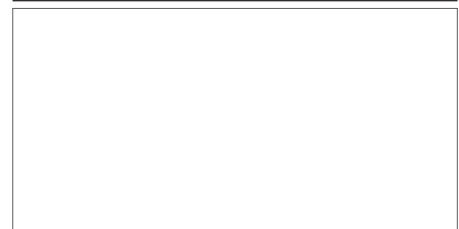

KIRLOSKAR BROTHERS LIMITED